



**FORKLIFT SALES & MANUFACTURER**



[TASKFORKLIFTS.COM](http://TASKFORKLIFTS.COM)



[INFO@TASKFORKLIFTS.COM](mailto:INFO@TASKFORKLIFTS.COM)



CALL US: (972) 522-7610

## + TASKVIPER® 4D 4-DIRECTIONAL REACH STACKER

### 4-DIRECTIONAL CONTROL.

The TASK® VIPER® 4D is designed with four-directional travel manoeuvrability, allowing operators to be smarter, more efficient and cause less damage to goods when handling larger loads.

The VIPER® 4D's revolving load wheels add a lateral axis of direction to the standard forward and reverse movement. This allows operators to travel sideways down narrower aisles with the same wide loads.

Built as standard with a tilting carriage, side-shift and pantographic reach, as well as the distinctive 4-directional travel system; all the functions including lift and lower are controlled using Task's VTC (Variable Total Control) module. This provides users with absolute control when operating the VIPER®.

### HANDLE MORE.

The VIPER® 4D reach truck eliminates the need for right-angle stacking; reducing the aisle widths required for handling large, heavy loads.

Whether you are handling long steel beams, large tubing, timber lengths or any other large materials, the VIPER® 4D's unique 4-directional mechanism enables outstanding useability and control resulting in less product damage.



# TASKVIPER® 4D

## 4D REACH STACKER

EMAIL: [INFO@TASKFORKLIFTS.COM](mailto:INFO@TASKFORKLIFTS.COM)

WEB: [TASKFORKLIFTS.COM](http://TASKFORKLIFTS.COM)

CALL US: (972) 522 7610

• DALLAS • SYDNEY • MELBOURNE • BRISBANE • ADELAIDE • SHANGHAI • SINGAPORE •



# 4D



138" & 177"  
Lift Height

4400 Lbs  
Capacity

4-Directional  
Travel

Pantographic  
Reach Stacker

## TECHNICAL INFO

	TWO STAGE	THREE STAGE
Lift Height Inches	138"	177"
A. Rated Capacity At 24" Inches L.C. (Lbs)	4400 Lbs	4400 Lbs
B. Lift Height Inches	138"	177"
C. Extended Height Inches With Load Backrest	185"	224"
D. Collapsed Height Inches	91"	85"
E. Free Lift Inches	Nil	36"
F. Chassis Length Inches (To Face of Forks)	53"	54"
G. Chassis Width Inches	36.5"	
H. Wheelbase Inches	63"	64"
I. Carriage Width Inches	32"	
J. Chassis Under Clearance Inches	4"	
K. Turning Radius Inches	73"	74"
L. Straddle I.D./O.D Inches	48" / 68"	
M/N. Rear // Forward Tilt	6° // 3°	
O. Reach Inches	24"	
P. Weight Less Battery Inches	4125 Lbs	4920 Lbs
Q. Battery Compartment Size Inches	31.5" Wide X 13.25" Long X 24" High	
R. Right Angle Stacking Aisle Inches	Dimension F + Load Length + 4 Inches	

## TECHNICAL INFO

 VIPER®-4D Technical Drawing

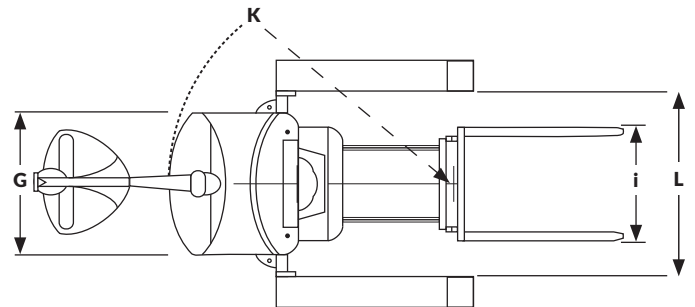
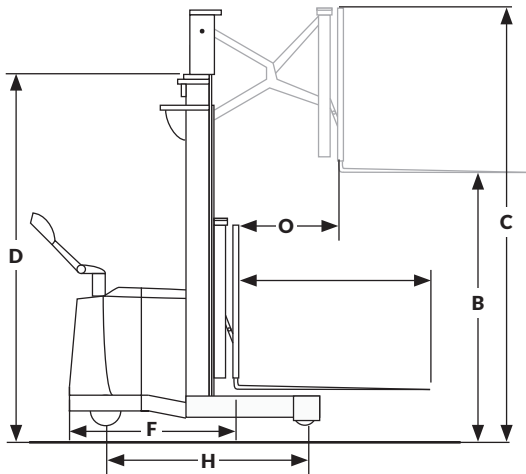

# TASKVIPER® 4D

## 4D REACH STACKER

Due to continuous product improvement, specifications are subject to change without notice or obligation. Some systems and features shown are optional at extra cost.

EMAIL: [INFO@TASKFORKLIFTS.COM](mailto:INFO@TASKFORKLIFTS.COM) WEB: [TASKFORKLIFTS.COM](http://TASKFORKLIFTS.COM) CALL US: (972) 522 7610

• DALLAS • SYDNEY • MELBOURNE • BRISBANE • ADELAIDE • SHANGHAI • SINGAPORE •